

# HUSKY CUP

The 16U Matches  
April 4-5, 2009



## TIER 1 DRAW

A	B
1. Sonics	2. Stoirm
4. Lakers	3. Colonels
5. Black Ice	6. Hurricanes

Record & Rank	A			
B		1	4	5
	2			
	3			
	6			

### Tier 1 Format

- In preliminaries, teams play a cross-over round robin - one match against each of the teams in the opposite pool. Results determine ranking within each pool.
- In the playoff round, the 2nd and 3rd place teams in each pool play each other in the quarterfinals. The winner plays the 1st place team within the same pool in the semifinals. The losing team plays a consolation placement match against the team losing its quarterfinal in the other pool. The semifinal winners play each other in the final, losing teams play for 3rd place.
- All teams play 5-6 matches.
- Medals will go to the top 2 teams, and there will be all-star and MVP presentations for this tier.

## PLAYOFFS

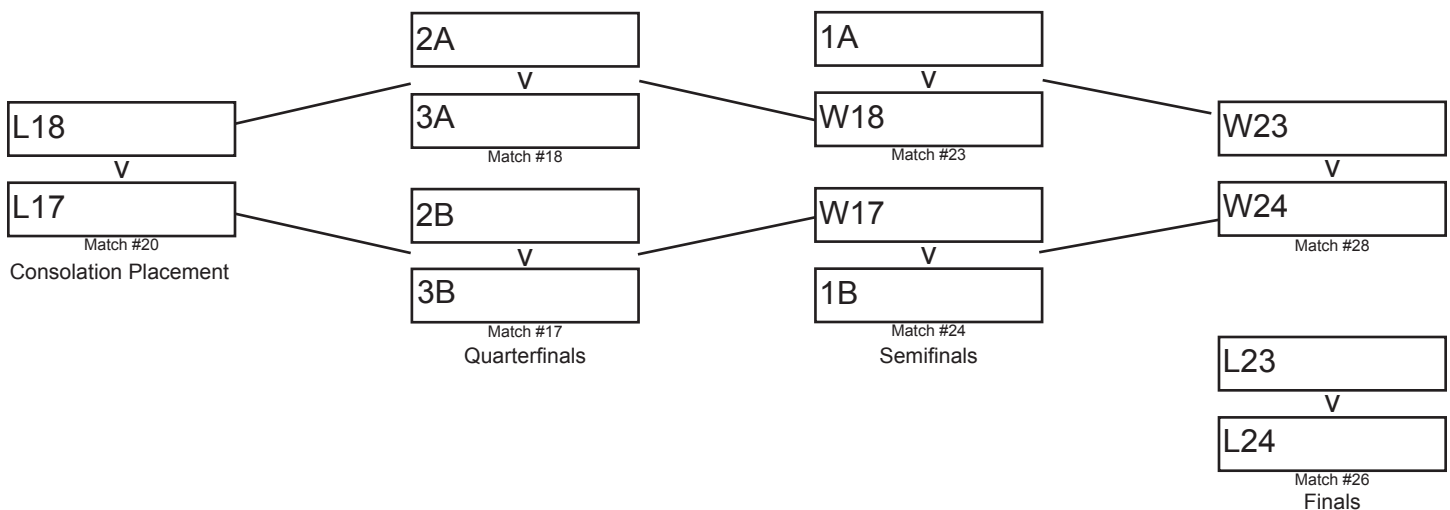

# HUSKY CUP

The 16U Matches  
April 4-5, 2009



## TIER 2

### DRAW

<b>C</b>
9. Lakers 15
10. Colonels 2
11. Stoirm Cyclone
12. Blizzard
13. Lightning Stoirm

Record & Rank	C	9	10	11	12	13
9						
10						
11						
12						
13						

### PLAYOFFS

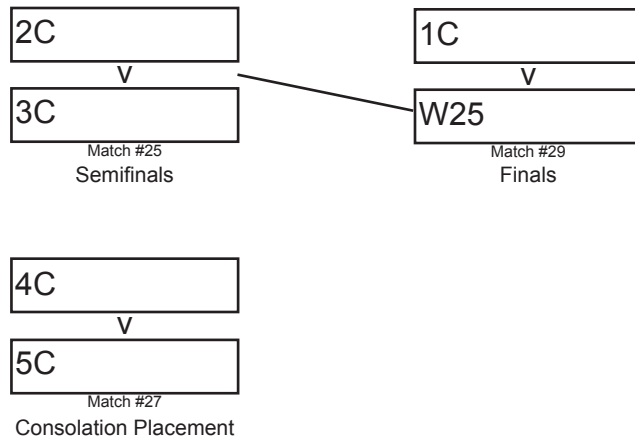

#### Tier 2 Format

- Teams play a 5-team round robin schedule for placement in the playoff round. The 2nd and 3rd place teams play in the semifinals, and the winner plays the 1st place team in the final. The 4th and 5th place teams play a consolation match.
- All teams play 5-6 matches.
- Medals will go to the top 2 teams, and there will be all-star and MVP presentations.

# HUSKY CUP

The 16U Matches

April 4-5, 2009



UNIVERSITY VOLLEYBALL

## SCHEDULE

A	B
1. Sonics	2. Stoirm
4. Lakers	3. Colonels
5. Black Ice	6. Hurricanes

C
9. Lakers 15
10. Colonels 2
11. Stoirm Cyclone
12. Blizzard
13. Lightning Stoirm

### DAY 1

Time	Match#	Court1	Match#	Court2	Match#	Court3
2:00	1	5 v 6	2	1 v 2	3	9 v 11
3:15	4	1 v 3	5	4 v 2	6	10 v 12
4:30	7	5 v 3	8	4 v 6	9	9 v 13
5:45	10	5 v 2	11	1 v 6	12	10 v 11
7:00	13	4 v 3	14	10 v 13	15	11 v 12
8:15					16	12 v 13

### DAY 2

Time	Match#	Court1	Match#	Court2	Match#	Court3
9:30	17	2B v 3B	18	2A v 3A	19	9 v 10
10:45	20	L17 v L18	21	11 v 13	22	9 v 12
12:00	23	1A v W18	24	1B v W17	25	2C v 3C
1:15	26	L23 v L24			27	4C v 5C
2:30	28	W23 v W24			29	1C v W25

#### Tournament Information:

- All matches 2 of 3 sets with 27/17 point caps except for final round.
- VC Youth level rules apply.
- Ball is Baden 15-0CM (very similar to Tach SV-5WI).
- Warm-up is 4 minutes at the net for each team - any serving must be done during this time. If a previous match goes over time, teams will have 10 minutes on-court including hitting warm-up (unless coaches agree to start sooner).
- Coaches have 2 time-outs, 30s each, and change-overs are 2 minutes.
- Teams will need to supply 1 scorekeeper for each match in which they are playing.
- There will be no athletic therapy or supplies available.
- Tie-break will be VC tie-breaking system - head to head, then sets for/against for teams involved, then sets for/against for all matches in pool play, then points for/against for teams involved, then points for/against for all matches in pool play, then coin toss.